

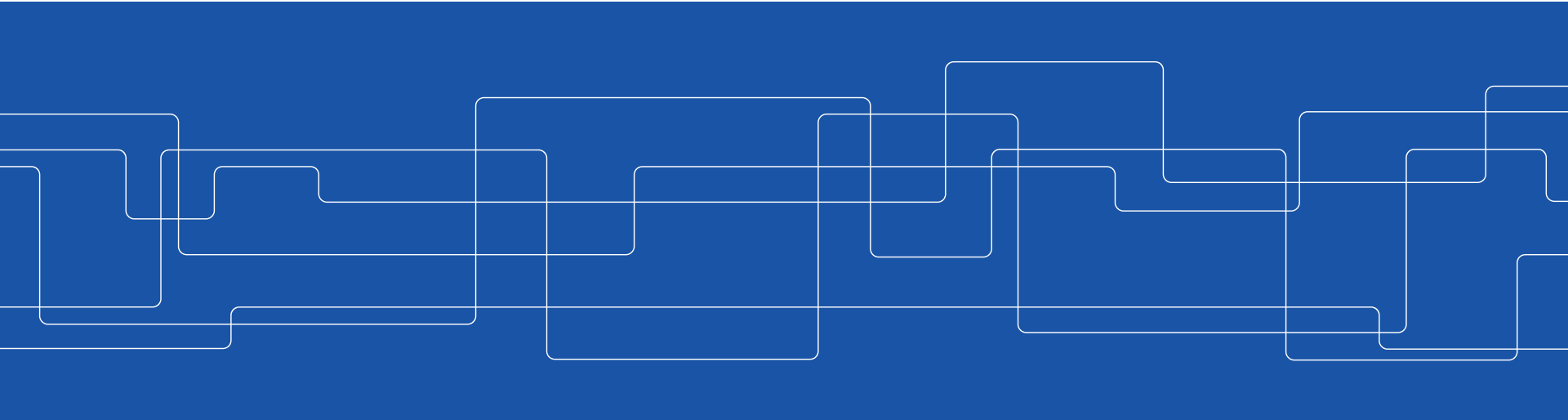

Energy Resources

Dr. Fahad Noor
Associate Professor
f.noor@uet.edu.pk

Engr. Adnan Qamar
Lecturer
adnan@uet.edu.pk





Wind Energy Resource

Winds are caused by the uneven heating of the atmosphere by the sun, the irregularities of the earth's surface, and rotation of the earth.

Wind flow patterns are modified by the earth's terrain, bodies of water, and vegetative cover. This wind flow, or motion energy, when "harvested" by modern wind turbines, can be used to generate electricity.



Wind Energy Resource

All renewable energy (except tidal and geothermal power), ultimately comes from the sun.

The earth receives 1.74×10^{17} watts of power (per hour) from the sun.

About one or 2 percent of this energy is converted to wind energy.



Wind Energy

On the market are converters with a capacity up to 8 MW.

The market introduction of wind energy is proceeding in industrialized countries as well as in developing countries like e.g. India.

The Indian wind energy sector had an installed capacity of 9,600 MW as end of 2008.

Table 1.1 Use of wind energy world wide

Status of installed wind power	Rated capacity	Share worldwide (%)
	1.1.2009 (MW)	
USA	25,200	21
Germany	23,900	20
Spain	16,800	14
China	12,200	10
India	9,600	8
Italy	3,700	3
France	3,400	3
UK	3,200	3
Denmark	3,100	2
Portugal	2,800	2
Remaining countries	16,700	14
Total	120,600	100



Wind Energy (Advantages)

- Wind energy systems are energized by the naturally flowing wind, therefore it can be considered as a clean source of energy.
- Wind energy does not pollute the air like power plants that rely on combustion of fossil fuels.
- Wind energy is available as a domestic source of energy in many countries worldwide and not confined to only few countries, as in case of oil.
- Wind energy is one of the lowest-priced renewable energy technologies available today.
- Wind turbines can also be built on farms, thus benefiting the economy in rural areas, where most of the best wind sites are found. Wind power plant owners make rent payments to the farmer or rancher for the use of the land.



Wind Energy (Disadvantages)

- The major challenge to using wind as a source of power is that the wind is intermittent and it does not always blow when electricity is needed.
- Wind energy cannot be stored; and not all winds can be harnessed to meet the timing of electricity demands.
- Good wind sites are often located in remote locations, far from cities where the electricity is needed. In developing countries, there is always the extra cost of laying grid for connecting remote wind farms to the supply network.
- Wind resource development may compete with other uses for the land and those alternative uses may be more highly valued than electricity generation.
- Although wind power plants have relatively little impact on the environment compared to other conventional power plants, there is some concern over the noise produced by the rotor blades, and aesthetic (visual) impacts.



On shore and Off Shore wind turbines





HAWT and VAWT

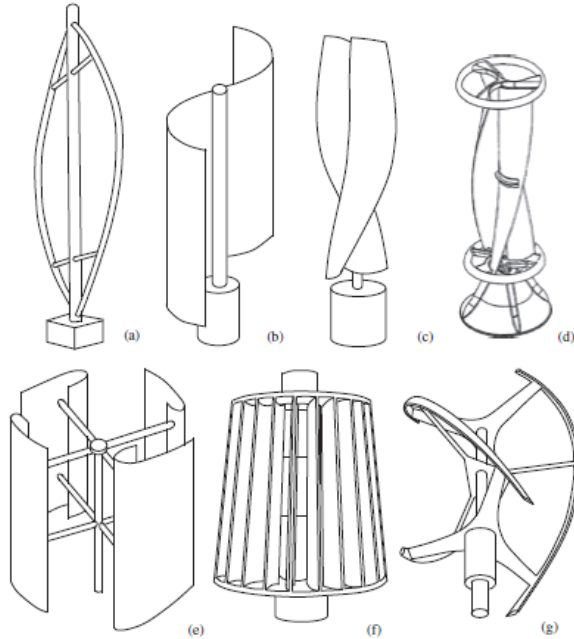

Figure 6: Several typical types of vertical-axis wind turbines: (a) Darrius; (b) Savonius; (c) Solarwind™ [36]; (d) Helical [37]; (e) Noguchi [38]; (f) Maglev [39]; (g) Cochrane [40].





Types of HAWT





Types of HAWT

Single blade HAWT

It reduces the cost and weight of the turbine. These are rarely used due to tower shadow effects, needs counter weights on the other side of the blade, less stability.

Two bladed HAWT

It requires more complex design due to sustain of wind shocks. It is also less stable. It saves the cost and weight of one rotor blade.

Three bladed HAWT

Modern wind turbines uses three blade concept. Because this structure have high strength to withstand heavy wind storms. Less effect due to tower shadow. Produces high output



Components of a Wind Turbine





Components of a Wind Turbine

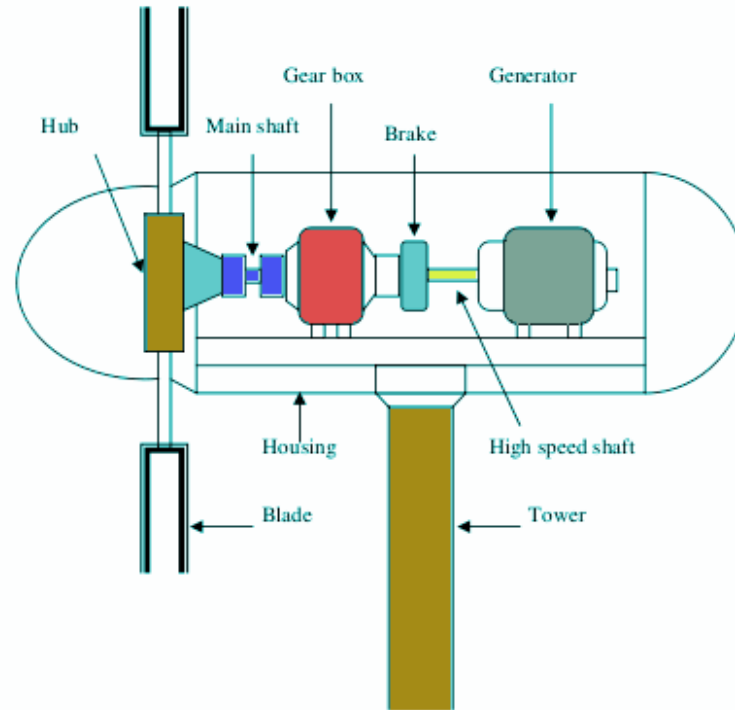



Classification of HAWT

- Rotor placement (upwind or downwind)
- The number of blades.
- The output regulation system for the generator.
- The hub connection to the rotor (rigid or hinged; the so-called “teetering hub”).
- Gearbox design (multi-stage gearbox with high speed generator; single stage gearbox with medium speed generator or direct drive with synchronous generator).



Classification of HAWT

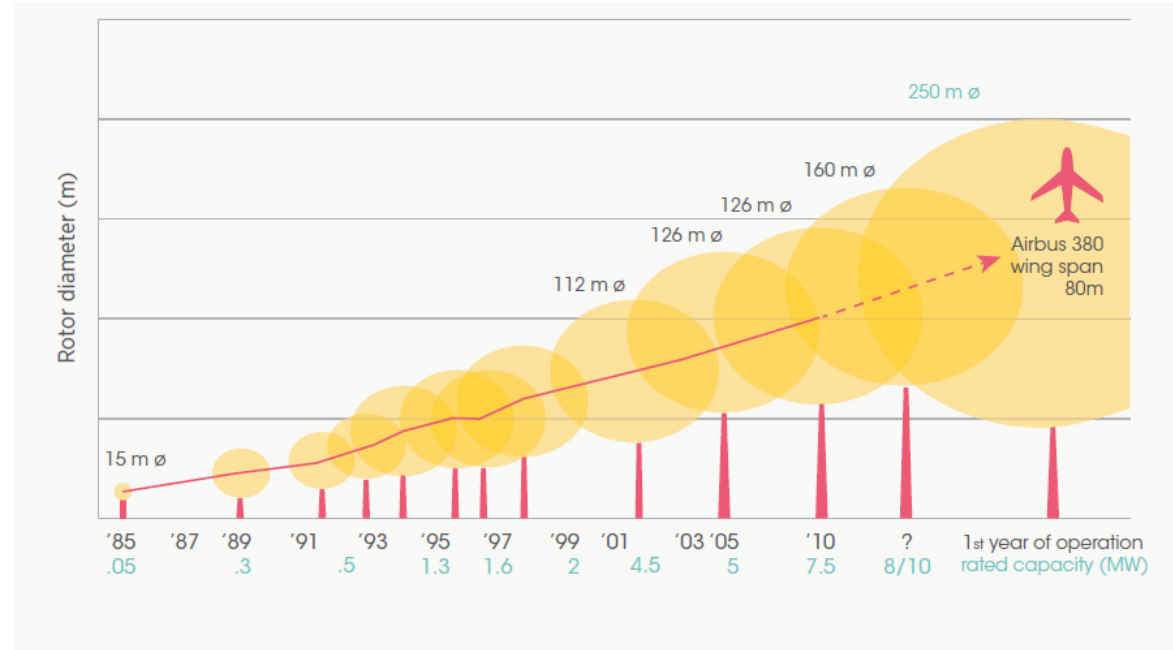
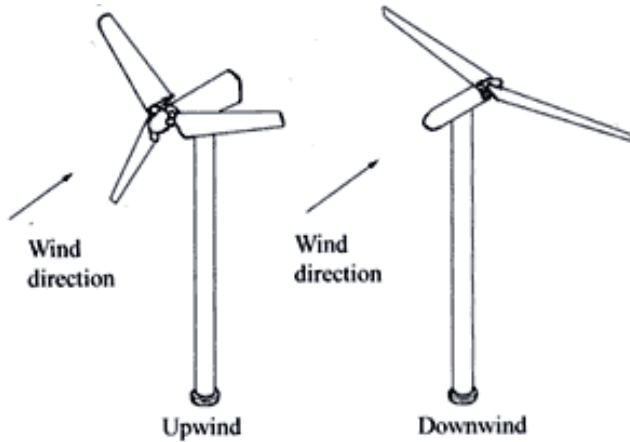

FIGURE 2.1: GROWTH IN THE SIZE OF WIND TURBINES SINCE 1985



Types of HAWT

Horizontal axis wind turbines (HAWTs), have the main rotor shaft and electrical generator at the top of a tower, and may be pointed into or out of the wind. Small turbines are pointed by a simple wind vane, while large turbines generally use a wind sensor coupled with a servo motor.



Types of HAWT

Advantages of HAWTs

- **Variable blade pitch**, which gives the turbine blades the optimum angle of attack.
- The tall tower base allows **access to stronger wind** in sites with wind shear. In some wind shear sites, every ten meters up, the wind speed can increase by 20% and the power output by 34%.
- **High efficiency**, since the blades always move perpendicularly to the wind, receiving power through the whole rotation.



Types of HAWT

Disadvantages of HAWTs

- Difficult to transport.
- Difficult to install, needing very tall and expensive cranes and skilled operators.
- Massive tower construction is required to support the heavy blades, gearbox, and generator.
- Reflections from tall HAWTs may affect side lobes of radar installations.
- Obtrusively visible across large areas, disrupting the appearance of the landscape and sometimes creating local opposition.
- Downwind variants suffer from fatigue and structural failure caused by turbulence when a blade passes through the tower's wind HAWTs require an additional yaw control mechanism to turn the blades toward the wind.



Types of VAWT

Vertical axis wind turbines (VAWTs), may be as efficient as current horizontal axis systems, might be practical , simpler and significantly cheaper to build and maintain than horizontal axis wind turbines.



Types of VAWT

Advantages of VAWTs

- They are always facing the wind – no need for steering into the wind.
- Have greater surface area for energy capture
- Are more efficient in gusty winds – already facing the gust
- Can be installed in more locations
- Do not kill birds and wild – life – slow moving and highly visible.
- Can be scaled more easily – from milliwatts to megawatts.
- Can be significantly less expensive to build
- Can have low maintenance downtime – mechanisms at or near ground level
- Produce less noise – low speed means less noise
- Are more esthetically pleasing – to some.



Terminology

Drag Force - component in line with the relative velocity

Lift Force - component perpendicular to F_D . The use of the word 'lift' does not mean F_L is necessarily upwards, and derives from the equivalent force on an airplane wing.

Angle of Attack The angle which an object makes with the direction of an air flow, measured against a reference line in the object.

Chord Line The reference from which measurements are made on an aero foil section

How Wind Power Works Turbine Aerodynamics

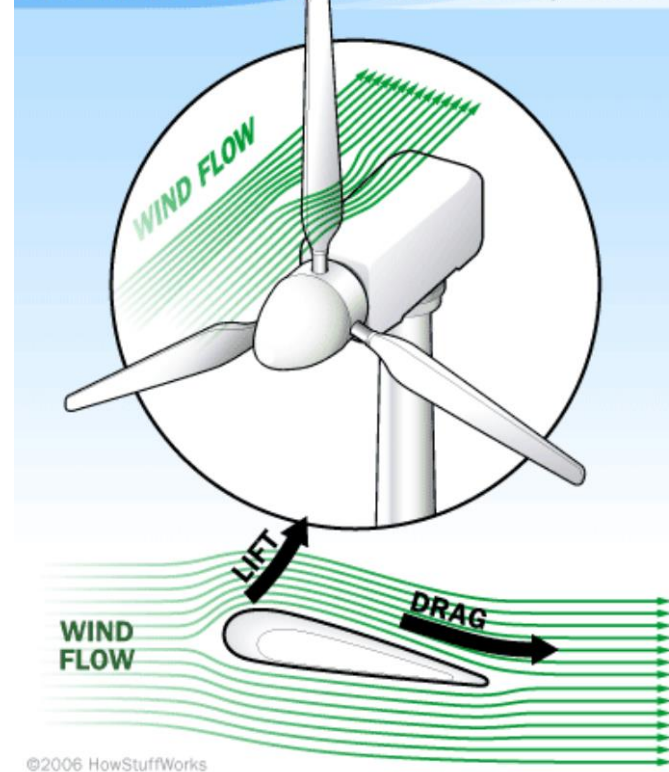

©2006 HowStuffWorks



Terminology

- **Solidity** - the ratio of the total area of the blades at any one moment in the direction of the airstream to the swept area across the airstream. Low solidity (high speed, low torque), High solidity (low speed, high torque)
- The **tip speed ratio (TSR)** is given by dividing the speed of the tips of the turbine blades by the speed of the wind.

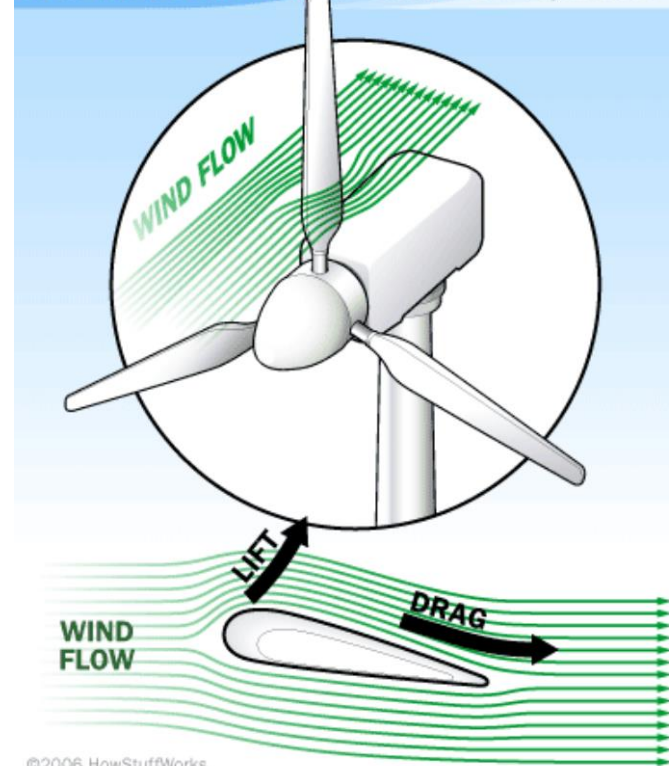



Terminology

- Optimum TSR depends on the number of blades in the wind turbine rotor. The **fewer the number of blades**, the **faster the wind turbine rotor** needs to turn to extract maximum power from the wind. A **two-bladed rotor** has an optimum tip speed ratio of around **6**, a **three-bladed rotor** around **5**, and a four-bladed rotor around **3**.

How Wind Power Works Turbine Aerodynamics

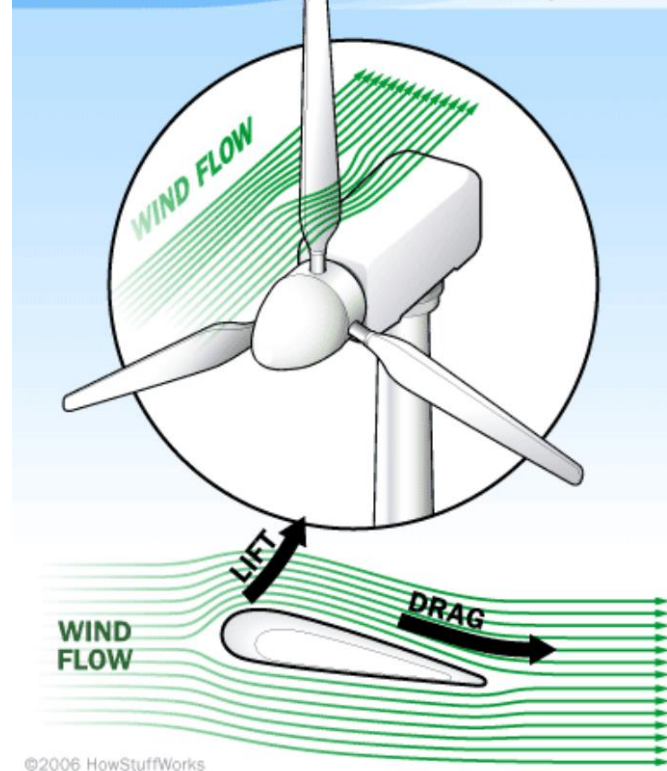

©2006 HowStuffWorks



Wind turbine capacity

Turbine Type	Power Capacity
Small	< 100 kW
Medium	100 kW to 1 MW
Large	> 1 MW
Ultra large	> 10 MW

In recent years, multi-megawatt wind turbines have become the mainstream of the international wind power market. Most wind farms presently use megawatt wind turbines, especially in offshore wind farms.



Power from Wind

$$E_k = \frac{1}{2} m \bar{u}^2$$

$$P_w = \frac{dE_k}{dt} = \frac{1}{2} \dot{m} \bar{u}^2$$

$$\dot{m} = \rho A \bar{u}$$

$$P_w = \frac{1}{2} \rho A \bar{u}^3$$

In order to obtain a higher wind power, it requires a higher wind speed, a longer length of blades for gaining a larger swept area, and a higher air density.

The wind power output is proportional to the cubic power of the mean wind speed, a small variation in wind speed can result in a large change in wind power.



Power from Wind

$$A = \pi \left[(l+r)^2 - r^2 \right] = \pi l (l+2r)$$

where l is the length of wind blades and r is the radius of the hub. Thus, by doubling the length of wind blades, the swept area can be increased by the factor up to 4.

When $l \gg 2r$,

$$A \approx \pi l^2$$

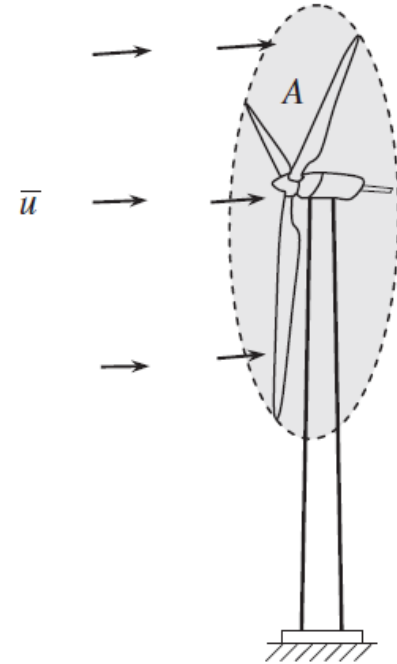

Figure 3: Swept area of wind turbine blades.



Wind power density

Wind power density is a comprehensive index in evaluating the wind resource at a particular site. It is the available wind power in airflow through a perpendicular cross-sectional unit area in a unit time period.

Table 1: Classes of wind power density [17].

Wind power class	10 m height		50 m height	
	Wind power density (W/m^2)	Mean wind speed (m/s)	Wind power density (W/m^2)	Mean wind speed (m/s)
1	<100	<4.4	<200	<5.6
2	100–150	4.4–5.1	200–300	5.6–6.4
3	150–200	5.1–5.6	300–400	6.4–7.0
4	200–250	5.6–6.0	400–500	7.0–7.5
5	250–300	6.0–6.4	500–600	7.5–8.0
6	300–350	6.4–7.0	600–800	8.0–8.8
7	>400	>7.0	>800	>8.8

For large-scale wind plants, class rating of 4 or higher is preferred.





Wind Characteristics

Wind speed varies in both time and space, determined by many factors such as geographic and weather conditions.

The wind speeds are higher in daytime and the maximum speed occurs at about 3 p.m., indicating that the daytime wind speed is proportional to the strength of sunlight.



Weibull distribution

The variation in wind speed at a particular site can be best described using the Weibull distribution function, which illustrates the probability of different mean wind speeds occurring at the site during a period of time

$$f(\bar{u}, k, \lambda) = \begin{cases} \frac{k}{\lambda} \left(\frac{\bar{u}}{\lambda}\right)^{k-1} \exp\left(-\left(\frac{\bar{u}}{\lambda}\right)^k\right) & \bar{u} \geq 0 \\ 0 & \bar{u} < 0 \end{cases}$$

It has been reported that Weibull distribution can give good fits to observed wind speed data.



Weibull distribution

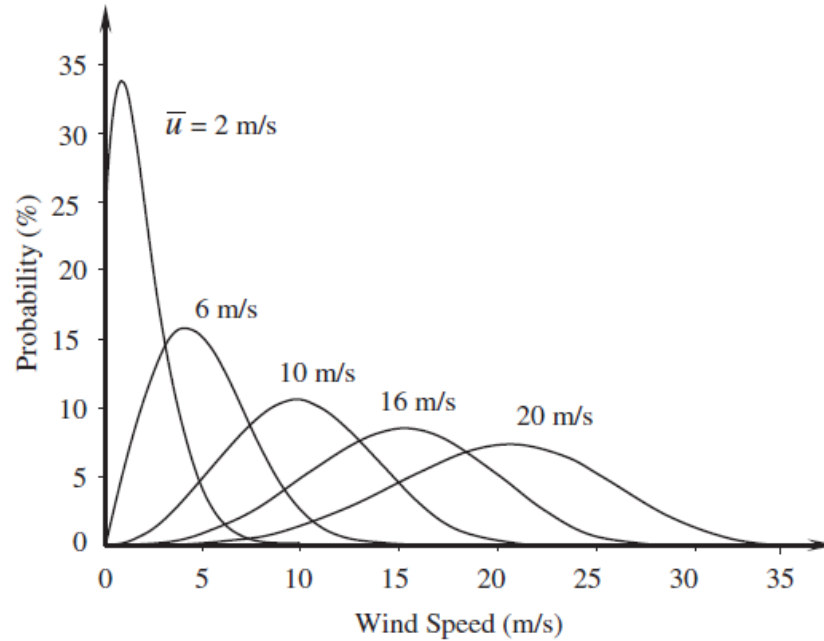

Figure 4: Weibull distributions for various mean wind speeds.



Wind Turbulence

Wind turbulence is the fluctuation in wind speed in short time scales, especially for the horizontal velocity component

$$u(t) = \bar{u} + u'(t)$$

$$I = \frac{\sigma_u}{\bar{u}}$$

Wind turbulence has a strong impact on the power output fluctuation of wind turbine. Heavy turbulence may generate large dynamic fatigue loads acting on the turbine and thus reduce the expected turbine lifetime or result in turbine failure.

In selection of wind farm sites, the knowledge of wind turbulence intensity is crucial for the stability of wind power production.



Wind Direction

Wind direction is one of the wind characteristics. Statistical data of wind directions over a long period of time is very important in the site selection of wind farm and the layout of wind turbines in the wind farm.

Some wind rose diagrams may also contain the information of wind speeds.

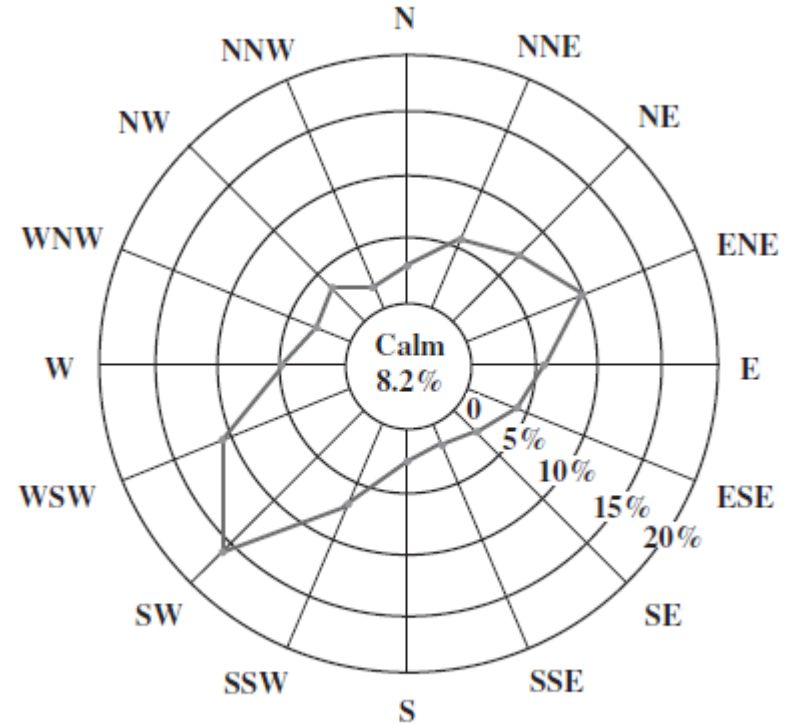

Figure 5: Wind rose diagram for wind directions.



Wind Shear

Wind shear is a meteorological phenomenon in which wind increases with the height above the ground.

$$u(z) = u(z_0) \left(\frac{z}{z_0} \right)^a$$

where z is the height above the earth's surface, z_0 is the reference height for which wind speed $u(z_0)$ is known, and a is the wind shear coefficient.

In practice, a depends on a number of factors, including the roughness of the surrounding landscape, height, time of day, season, and locations. The wind shear coefficient is generally lower in daytime and higher at night. Empirical results indicate that wind shear often follows the “1/7 power law” (i.e. $a = 1/7$).



Power coefficient

The conversion of wind energy to electrical energy involves primarily two stages:

In the first stage, kinetic energy in wind is converted into mechanical energy to drive the shaft of a wind generator. The critical converting devices in this stage are wind blades. For maximizing the capture of wind energy, wind blades need to be carefully designed.

The real power coefficient C_p is much lower than its theoretical limit, usually ranging from **30 to 45%**

$$C_p = \frac{P_{me,out}}{P_w} = \frac{P_{me,out}}{(1/2)\rho A \bar{u}^3}$$



Effective power output

$$\eta_t = C_p \eta_{\text{gear}} \eta_{\text{gen}} \eta_{\text{ele}}$$

$$P_{\text{eff}} = C_p \eta_{\text{gear}} \eta_{\text{gen}} \eta_{\text{ele}} P_w = \eta_t P_w = \frac{1}{2} (\eta_t \rho A \bar{u}^3)$$

Gearbox efficiency η_{gear}

Generator efficiency η_{gen}

Electric efficiency η_{ele}



Lanchester-Betz Limit

The theoretical maximum efficiency of an ideal wind turbomachine was derived by Lanchester in 1915 and Betz in 1920. It was revealed that **no wind turbomachines could convert more than 16/27 (59.26%) of the kinetic energy of wind into mechanical energy.**

This is known as Lanchester–Betz limit (or Lanchester-Betz law) today.



Power coefficient

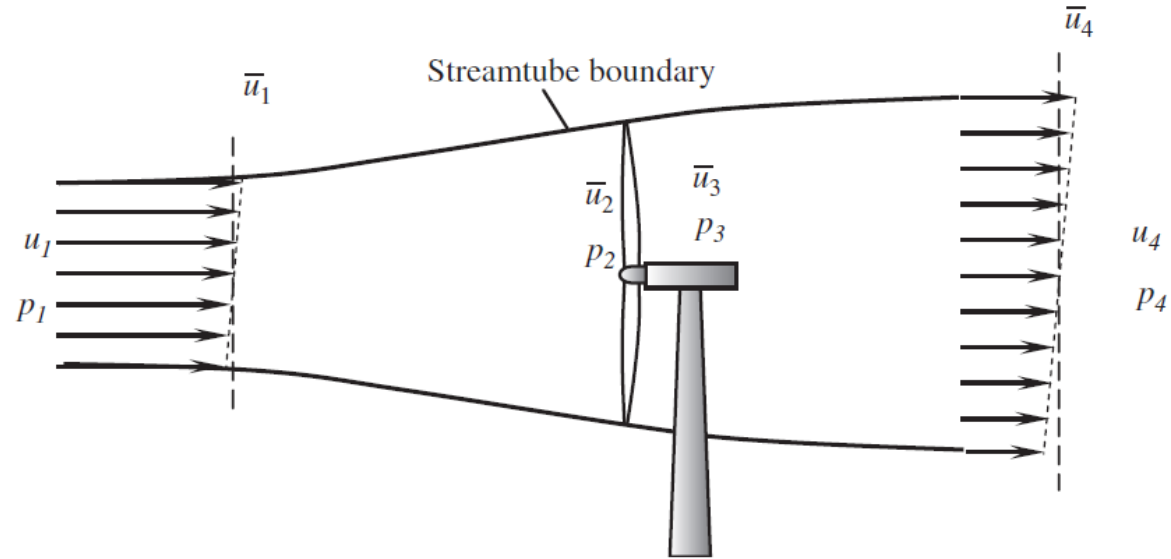

Figure 8: Airflow through a wind turbine.



Power coefficient

$$P_{\text{me,out}} = \frac{1}{2} \rho A \bar{u}_2 (\bar{u}_1^2 - \bar{u}_4^2) = \frac{1}{2} \rho A \bar{u}_1^3 4a(1-a)^2$$

$$a = \frac{\bar{u}_1 - \bar{u}_2}{\bar{u}_1}$$

$$C_p = \frac{P_{\text{me,out}}}{P_w} = \frac{P_{\text{me,out}}}{(1/2) \rho A \bar{u}^3}$$

$$C_p = 4a(1-a)^2$$

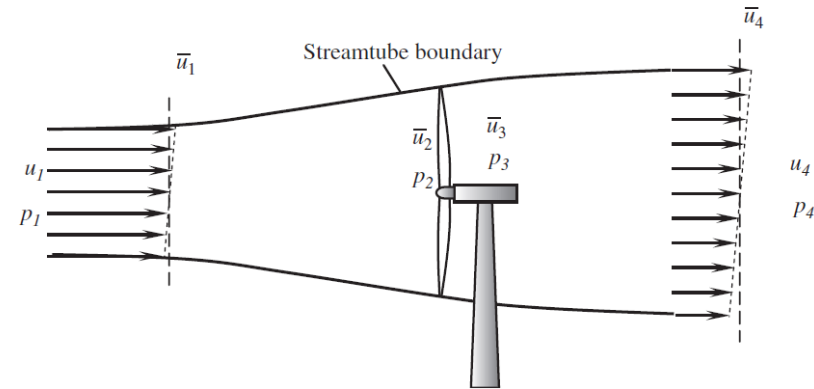

Figure 8: Airflow through a wind turbine.



Power coefficient

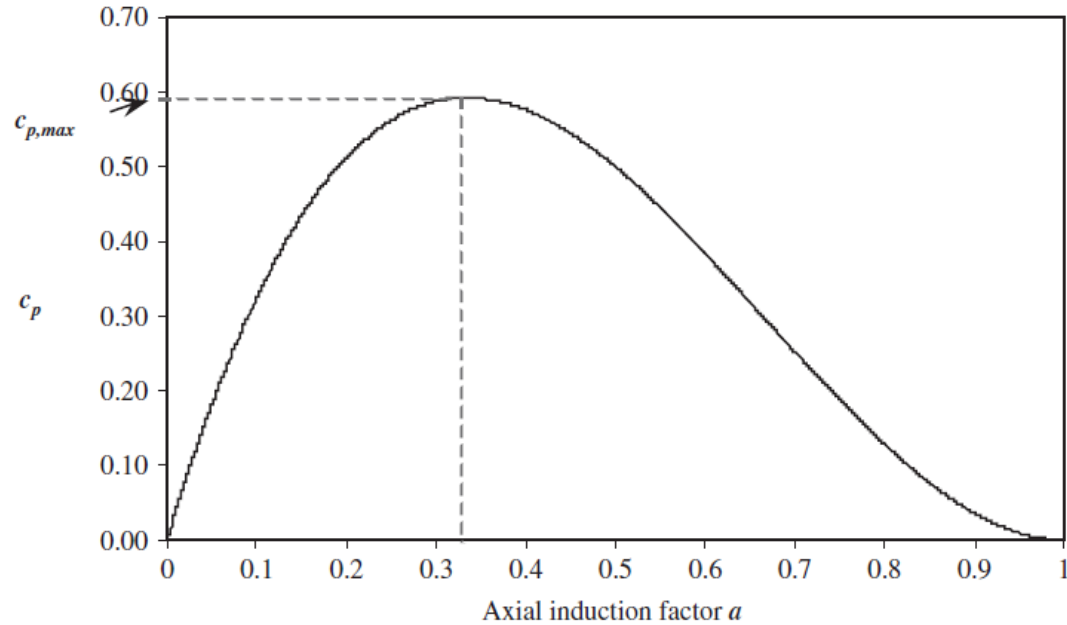

Figure 9: Power coefficient as a function of axial induction factor a .



Wind Power Curve

A wind turbine is usually designed to reach full rated power at wind velocities of around **12–15 m/s**.

It mostly runs at **part-load**, as the wind is not always strong enough.

The turbine should be able to efficiently convert power from weak winds, therefore it is often designed to reach full efficiency at around **8 – 10 m/s** wind speed.

Also in stronger winds the turbine **must decrease its output** to protect the generator from overloading, i.e. at strong winds the turbine dumps energy and works at lower efficiency.



Wind Power Curve

The power curve of a wind turbine is a graph that indicates how large the electrical power output will be for the turbine at different wind speeds.

This is the **speed** at which the **turbine** blades are brought to **rest** to avoid damage from high winds.

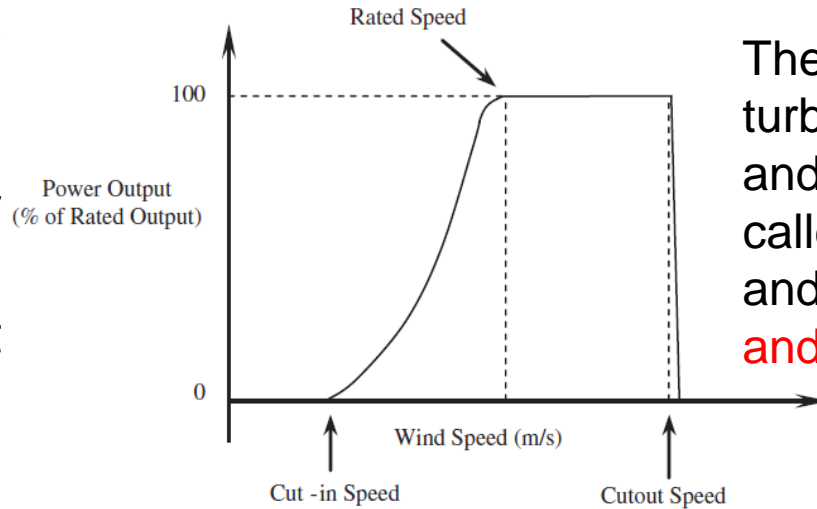

The **speed** at which the turbine first starts to rotate and generate power is called the **cut-in speed** and is typically between **3 and 4 metres per second**.

Figure 10: Typical wind turbine power curve.



Tip speed ratio

The tip speed ratio is an extremely important factor in wind turbine design, which is defined as the ratio of the tangential speed at the blade tip to the actual wind speed.

$$\lambda = \frac{(l+r)\omega}{\bar{u}}$$

where l is the length of the blade, r is the radius of the hub, and ω is the angular speed of blades.



Tip speed ratio

Optimal rotational speed

$$\omega_{\text{opt}} \approx \frac{2\pi \bar{u}}{n L}$$

where L is the length of the strongly disturbed air stream upwind and downwind of the rotor.

$$\lambda_{\text{opt}} \approx \frac{2\pi}{n} \left(\frac{l+r}{L} \right)$$

Empirically, the ratio $(l+r)/L$ is equal to about 2. Thus, for three-blade wind turbines (i.e. $n = 3$), $\lambda_{\text{opt}} \approx 4\pi/3$.



Wind turbine capacity factor

A capacity factor of a wind turbine is used to provide a measure of the wind turbine's actual power output in a given period (e.g. a year) divided by its power output if the turbine has operated the entire time.

A reasonable capacity factor would be 0.25–0.30 and a very good capacity factor would be around 0.40.



Wind turbine controls

Under high wind speed conditions, the power output from a wind turbine may exceed its rated value. Thus, power control is required to control the power output within allowable fluctuations for avoiding turbine damage and stabilizing the power output.

- Pitch control
- Stall control



Wind turbine control

Pitch control

The pitch control system not only continually regulates the wind turbine's blade pitch angle to enhance the efficiency of wind energy conversion and power generation stability, but also serves as the security system in case of high wind speeds or emergency situations.

It requires that even in the event of grid power failure, the rotor blades can be still driven into their feathered positions by using either the power of backup batteries or capacitors or mechanical energy storage devices.



Wind turbine control

The hydraulic pitch control system uses a hydraulic actuator to drive the blade rotating with respect to its axial centerline. The most significant advantages of hydraulic pitch control system include its large driving power, lack of a gearbox, and robust backup power.

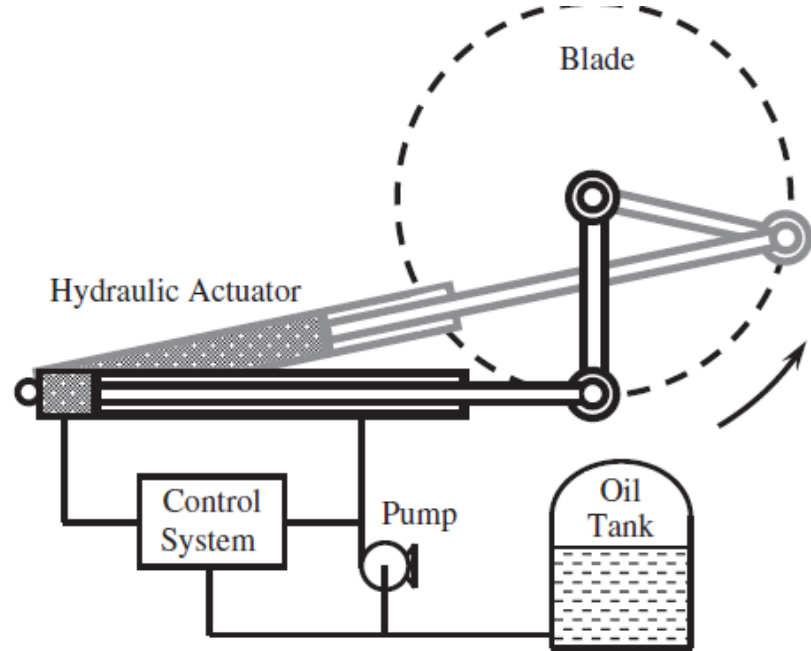

Figure 11: Hydraulic pitch control system.



Wind turbine control

This type of control system has a higher efficiency than that of hydraulic controlled systems (which is usually less than 55%) and avoids the risk of environmental pollution due to hydraulic fluid being split or leaked.

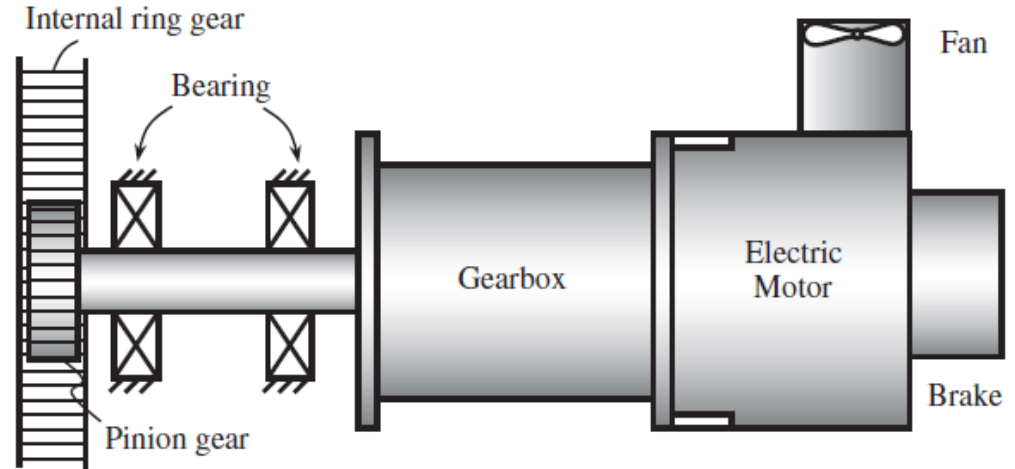

Figure 12: Electric pitch control system.



Wind Energy and Pakistan



Wind Energy and Pakistan

The estimated energy potential of the wind corridor is 50,000MW.

Wind power generation capacity of the country is projected to increase from 250 to 1,530MW.

Pakistan has a 1,046 km coastline in the South (Sindh and Balochistan), but most of the wind power projects are currently being installed at Gharo-Keti Bander and Hyderabad wind corridor.



Wind Energy and Pakistan

Presently five WTG projects each with 50MW capacity are operating at Gharo-Jhampir wind corridor. However, the nine other WTG projects which are in the phase of development will produce 450MW and those in the stage of construction will produce 480MW wind energy. Similarly, four projects which have been given Lols will produce 350MW.



Wind Energy and Pakistan

Wind Farms

When wind turbines are grouped together, they are referred to as “wind farms”. Wind farms comprise the turbines themselves, plus roads for site access, buildings (if any) and the grid connection point.





Wind Energy and Pakistan

Jimphir Wind Power Plant

The Jhimpir Wind Power Plant is a wind farm located at Jhimpir in Thatta District of Sindh province in Pakistan.

The project has been developed by Zorlu Energy Pakistan, a subsidiary of the Turkish firm Zorlu Enerji.

The total cost of project is \$143 million.

The capacity of the project to 56.4 MW. The project was completed in March 2013



Wind Energy and Pakistan

FOUNDATION WIND ENERGY - I LIMITED

M/s Nordex Germany (Lead) & M/s Descon Engineering Limited consortium. FWEL-I has installed **20 x 2.5 MW** Nordex (Model N-100) wind turbine generators.

FWEL-I project site is located at Khutti Kun New Island in the Taluka Mirpu Sakro of Thatta District.

The project achieved commercial operations (COD) on 11 April 2015.

As per EPA signed, the project has to generate 144.5 GWH annually at capacity factor of 33%.

The project is registered with CDM, UNFCCC under KYOTO Protocol. It is expected to earn around 80,000 CERs (Carbon credits) annually.



Wind Energy and Pakistan

Master Wind Energy Limited (MWEL) is Master Group's first foray into the energy business.

It is a 52.8 MW Wind power project located in Jhimpir Sindh currently in the construction phase.

The wind farm is situated on 1,408 acres of land.

The project will generate electricity through 33 x 1.5 MW GE turbines.



Wind Energy and Pakistan

Year	O&M Rs. / kWh	Insurance Rs. / kWh	ROE Rs. / kWh	Principal + Interest Rs. / kWh	Tariff Rs. / kWh
1 – 10	1.6040	0.7833	4.8341	10.4259	17.6473
11 – 20	1.6040	0.7833	4.8341	-	7.2221
Levelized					14.7462
Indexation	PKR / USD & US CPI	PKR / USD	PKR / USD	KIBOR/LIBOR	



Typical New Wind Farms and Performance

TABLE 1: TYPICAL NEW WIND FARM COSTS AND PERFORMANCE IN 2010

	Installed cost (2010 USD/kW)	Capacity factor (%)	Operations and maintenance (USD/kWh)	LCOE* (USD/kWh)
Onshore				
China/India	1 300 to 1 450	20 to 30	n.a.	0.06 to 0.11
Europe	1 850 to 2 100	25 to 35	0.013 to 0.025	0.08 to 0.14
North America	2 000 to 2 200	30 to 45	0.005 to 0.015	0.07 to 0.11
Offshore				
Europe	4 000 to 4 500	40 to 50	0.027 to 0.048	0.14 to 0.19

* Assumes a 10% cost of capital



Renewable Power Generation Cost Indicators

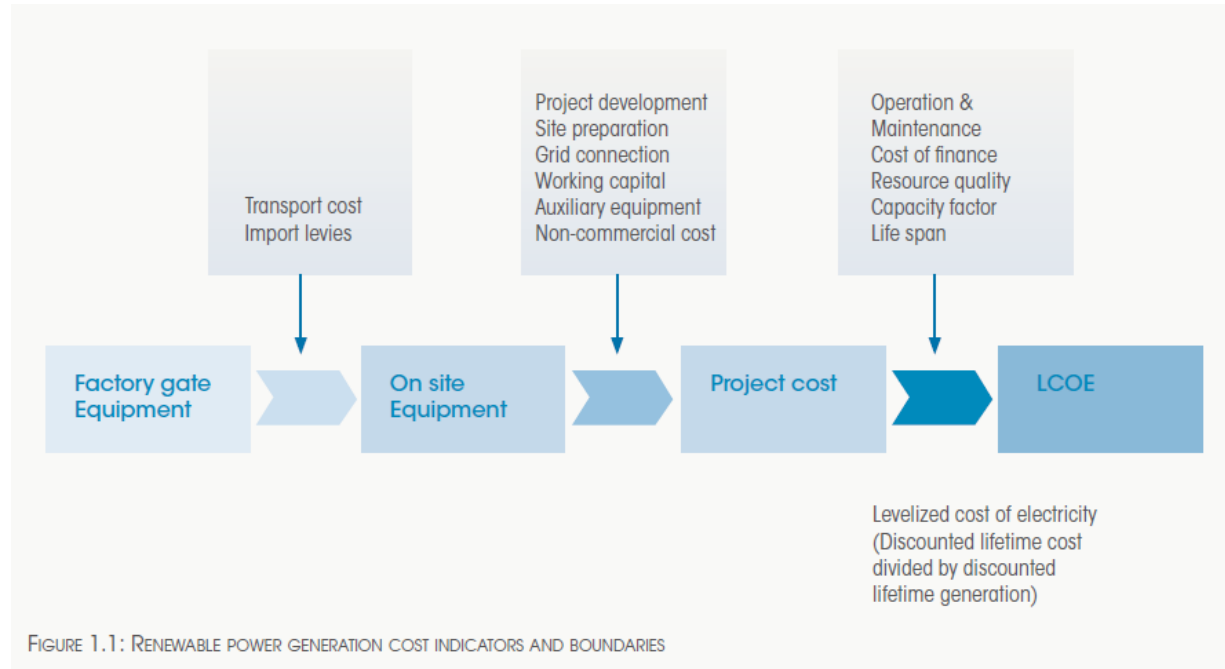



World's largest Wind Turbine

MHI Vestas V164 8MW

- 8MW rated power, with an optimal rotor to generator ratio.
- 80m blades, the equivalent of nine double decker London buses.
- Swept area of 21.124m^2 , larger than the London Eye.
- The nacelle is 24 m long, 12 m wide and 7.5 m high, weighing approximately 390 tonnes.
- Approximate hub height of 105 m.
- Approximate tip height of 187m.





Wind Power Density

Kinetic Energy (KE) – $\frac{1}{2} mV^2$

For a constant wind speed v , normal cross sectional area A , and given period of time, t , and air density ρ ,

- Air mass $m = \rho AVt$

So,

$$KE = \frac{1}{2} \rho AtV^3$$

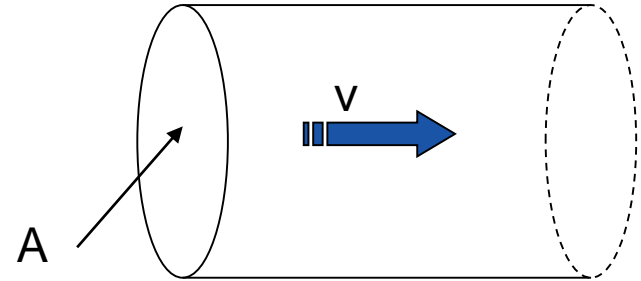

Wind power density (per unit area and per second) is:

$$\text{Power} = \frac{1}{2} \rho V^3$$



Wind Energy Resource

- A typical 600 kW wind turbine has a rotor diameter of 43-44 meters, i.e. a rotor area of some 1,500 square meters.
- The rotor area determines how much energy a wind turbine is able to harvest from the wind.
- Since the rotor area increases with the square of the rotor diameter, a turbine which is twice as large will receive $2^2 = 2 \times 2 =$ four times as much energy.
- To be considered a good location for wind energy, an area needs to have average annual wind speeds of at least 12 miles per hour (5.3 m/s).



Wind Energy Resource

Data tend to be recorded at a relatively few permanently staffed official stations using robust and trusted equipment.

Official measurements of wind speed tend to be measured only at the one standard height of 10 m.

Measurements at the nominated site at several heights are needed to predict the power produced by particular turbines.



Wind Shear

Wind speed varies considerably with height above ground; this is referred to as wind shear. A machine with a hub height of (say) 30 m above other obstacles will experience far stronger winds than a person at ground level.



Wind Shear

The wind tower should be kept far away from the local barrier to the wind.

Selected area should be enyos of the greater part of the zone.



Thank You